

# TB-3700

**Options: TB-3700****Variations: 3Phase only**

Motor Rating: 3.7kw

Inlet Connection: Flange/Spigot

Outlet Connection: Flange/Spigot

Outlet Diameter: 6"

Inlet damper: Supplied as standard

Supply Frequency: 50/60Hz

Single phase 110/240 Vac, 50/60Hz

Three phase 208-255/360-440 Vac, 50/60Hz

Maximum pressure: 350/400mmAq

Maximum vacuum: 350/400mmAq \*

Flow rate: up to 2100/2700m<sup>3</sup>/hour

Weight: 74kg

Noise level: 80/100dB(A)

**Airtec Centrifugal Blowers**

Airtec Air Systems supply an unrivalled range of centrifugal blowers to a variety of industrial markets. This enables us to offer the widest choice of products to match your exact requirement. Standard features of the range include robust, corrosion resistant, epoxy resin coated cast aluminium housings suitable even for the most demanding applications. Stainless steel or corrosion resistant polypropylene housings are also available. Reliability is assured by the use of motors that are insulated to the highest class H specification. Energy efficient EFF1 and EPACT motors are also available on the entire range.

**The Centrifugal Blower Principle**

As the impeller starts to rotate, air is sucked into the inlet and directed in a centrifugal outward motion to the edge of the impeller and exits the outlet port. Relative to Side Channel Blowers, much higher volumes at lower pressures are achieved. Process can be connected to the outlet for blowing or to the inlet for vacuum

**Construction**

All units are equipped with a low-noise, high-efficiency, class H insulated IP54 induction motors. Constructed from Cast aluminium alloy, all of Airtecs blowers are extremely robust, corrosion resistant and are suitable for the most demanding applications. They can operate continuously for a long period of time under a high temperature of up to 40 degrees Celsius. Units are suitable for an inlet temperature of up to 160 degrees C.

**Installation - Supply requirements**

Our centrifugal blowers are available for a wide range of supply voltages:

- single phase 110/240 Vac, 50/60Hz
- three phase 208-255/360-440 Vac, 50/60Hz

These voltage ranges are accessible via simple link changes within the supply terminal connection box mounted on top of the blower. Frequency invertors may be employed to vary the pressure/vacuum and volume flow rate to improve efficiency and fine tune the performance for a particular application. All units are continually rated and are suitable for supply frequencies in the range 40Hz (minimum) to 70Hz (maximum).

**Installation - Mechanical**

The bases of all our blower models are made with flexible steel plates that feature shock absorption. Locating holes on the blowers mounting plate enable both horizontal and vertical mountings of the blower.

**Applications**

Some common applications include: Process cooling, air knife applications, fume/heat extraction, aeration, process drying.

**Accessories**

A range of accessories is available. Including inlet air filters, outlet adapters, hosing, etc.

# TB-3700

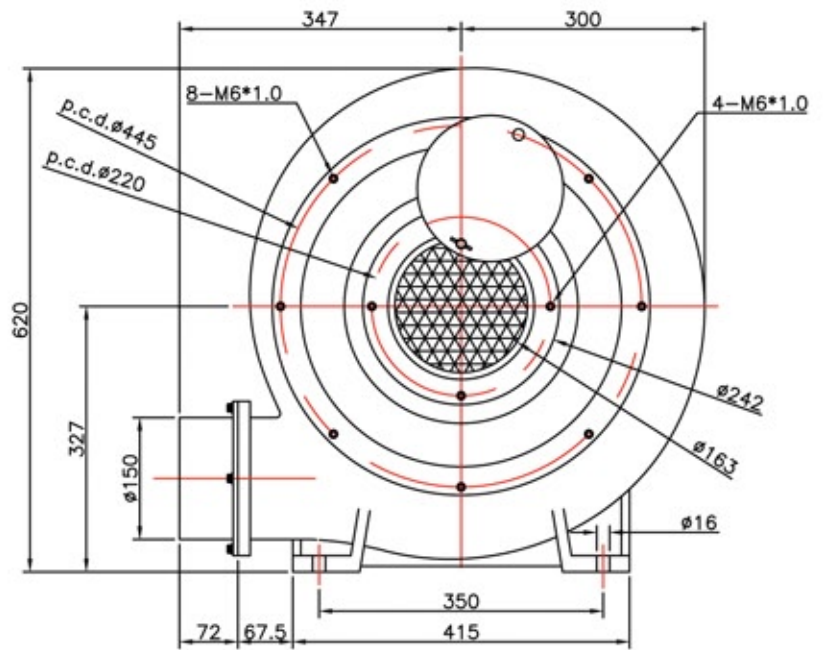
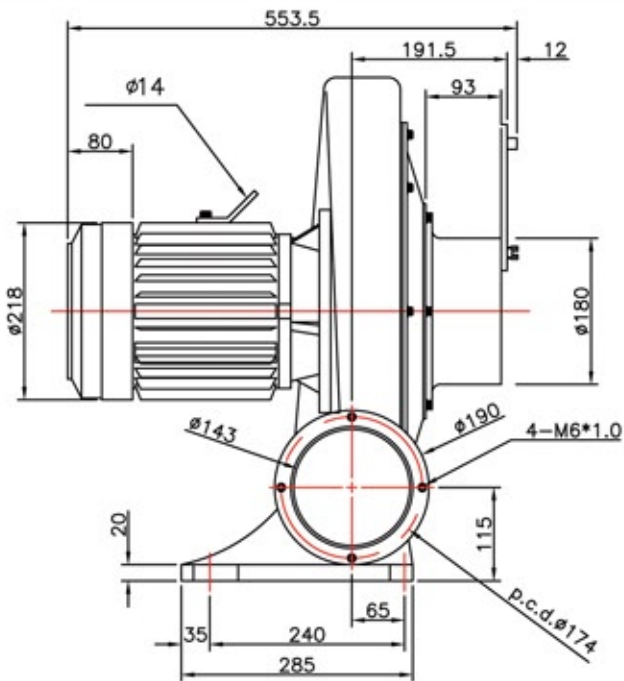

mm AQ

